

The History of UV and Wastewater

G. Elliott Whitby^{1,2} and O. Karl Scheible³

¹ Corresponding Author; Email: ewhitby@calgoncarbon-us.com

² Calgon Carbon Corporation, 50 Mural St., Unit 3, Richmond Hill, Ontario, Canada L4B 1E4

³ HydroQual, Inc. 1200 MacArthur Blvd., Mawah, NJ 07430

ABSTRACT

Ultraviolet radiation is accepted and widely applied for the disinfection of treated wastewaters, including reuse waters. Although the technology was discovered more than a century ago, its practical development is more recent, driven by regulatory demands to seek alternates to chlorination. The application of UV to treated wastewaters has seen rapid growth over the past 25 years, with the number of plants today numbering more than four thousand. The unique design considerations for wastewater applications have led to today's conventional configurations of open-channel, gravity flow, modular systems, with current and future research focusing on the impact of water quality, and the optimization of reactor design using biosimetry and hydraulic modeling techniques. This paper explores the history of the technology and the system design and research activities surrounding its application to treated wastewaters.

Keywords: Ultraviolet radiation; wastewater disinfection; reuse water disinfection; biosimetry; UV process modeling; history; photoreactivation; open-channel; low-pressure lamps; medium-pressure lamps; CFD; dose-distribution

INTRODUCTION

The use of ultraviolet (UV) radiation to disinfect wastewaters has an interesting and relatively new history. This paper reviews the practice of UV disinfection of wastewater from its inception in the late 1970's up to the present time. The authors do this from the perspective of three drivers that influenced the technology's growth: (1) regulatory interest, (2) effective and efficient technology development for wastewater applications, and (3) research that showed that UV light will reliably disinfect wastewater. Certainly, an undertaking of this kind will likely leave out some key points and may overly reflect the authors' own experiences, but it is interesting to reflect on the growth of a new technology in an application that was already well established and effective. One can say that the ongoing interest and growth of UV in the water industry has strong similarities to its development for wastewaters.

THE REGULATORY INCENTIVE

One can speculate that UV would not have developed to any significant degree without the regulatory pushes with regard to the environmental impacts of the use of chlorine and the increased precautions relating to its safe handling, storage and transport. Chlorination is very effective, so without these issues, none of which reflect on disinfection performance, it is likely that chlorine would have remained the disinfectant of choice.

Removing Halogen and Disinfection By-Products from the Environment

The practice of wastewater disinfection is rooted in two basic and complementary principles: the protection of human health, and the maintenance of a natural, healthy environment. Inactivation or destruction of pathogenic microorganisms at municipal treatment plants can reduce the dissemination of pathogens to the environment and break the potential cycles of pathogen-associated infections. Chlorination became the standard process for disinfecting treated wastewaters, and was the key to the great public health successes of the 20th century. But, as we became aware of the environmental impacts associated with disinfection practices in the 1960's and 1970's, regulators determined that the ongoing need to effectively destroy pathogenic microorganisms must be balanced against the effects of a disinfected wastewater on the biota in receiving water and the creation of by-products that in themselves had serious public-health consequences. The deleterious effects of halogens on the environment have been well documented along with the long-term effects of halogenated hydrocarbons. In the 1970's this prompted governments throughout North America (USEPA 1976; Environment Canada 1978) to reduce the levels of chlorine and its by-products from disinfected wastewater (Riordan 1979). More restrictive limits began to be placed on chlorine residuals, often requiring dechlorination before discharge. The investigation and implementation of alternative disinfection methods was encouraged, prompting a considerable amount of research and demonstration efforts with ozone, bromine chloride, chlorine dioxide and UV.

Addressing Safety Issues Relating to Chlorination

In the late 1980's and 1990's, as legislation and regulations were passed to strengthen the control of hazardous chemicals and community right-to-know protocols, the hazards of transporting and storing gaseous chlorine (and sulfur dioxide in cases where dechlorination was practiced) received greater attention. This gave an economic incentive for finding effective alternatives to chlorination. National and statewide fire codes require secondary containment for gaseous chlorine releases, and local emergency response protocols and community awareness add costs to the maintenance of chlorination activities.

Rather than being driven by the potential, but largely unknown, technological and economic advantages of UV, it is evident that the first influence in the development of UV was from the regulatory side – the need for an alternative technology that would do as well as chlorination, but mitigate peripheral, but serious, issues relating to the use of chlorine. UV was new to the industry, and probably the least understood when compared to the alternative chemical oxidants such as ozone. But the interest in UV was heightened by its sometime unique advantages, as shown in Table 1. Probably the most important was that using UV light to disinfect wastewater does not produce any toxic by-products during or after the disinfection process.

Table 1: The advantages of UV light for disinfecting wastewater.

- UV light kills viruses, vegetative and spore-forming bacteria, *Cryptosporidium*, *Giardia*, algae and yeasts,
- no chemicals are added to the wastewater to change the pH, conductivity, odour, taste or create possible toxic compounds,
- impossible to irradiate the water with too much UV light,
- freedom from handling and storing dangerous toxic chemicals such as chlorine or other related compounds,
- Uniform Fire Code in the United States,
- shorter retention time for disinfection eliminates the need for large contact chambers,
- relatively simple equipment and operation, and
- possible capital and operating cost savings.

UV EQUIPMENT DEVELOPMENT

Addressing UV Equipment Design for Wastewater Applications

In the latter part of the 19th Century, it was shown that UV light inactivates microorganisms (Downes and Blunt 1878–1879). The subsequent development of UV equipment became dependent on people integrating the latest developments in the fields of lamps, ballasts and sensor technologies. Table 2 shows some of the major events and trends that affected the development of effective UV disinfection systems. UV light was used to disinfect drinking water as early as 1906 (von Recklinghausen 1914). At that time no one disinfected wastewater. The introduction of chlorination essentially eliminated the use of UV for disinfecting drinking water in North America, but not Europe. The experience with chlorine and drinking water was transferred to wastewater in North America and UV was

never adopted as a conventional disinfectant agent for water or wastewater applications. In the late 1970's the United States Environmental Protection Agency (USEPA) started to discourage the use of chlorine for disinfecting wastewater and provided research money and construction grants for UV disinfection. The USEPA's Innovative and Alternative (I&A) Technology program was responsible for securing the installation of several full-scale UV systems throughout the country. These installations, although not without problems, enabled the industry to demonstrate UV's effectiveness and to support developments that improved its design. Clearly, UV disinfection of wastewaters can be considered a success for the I&A program.

Table 2: Important milestones in the advancement of UV disinfection

- Downes and Blunt in 1878 discovered that sunlight kills microbes in broth.
- Bernard and Morgan in 1903 and Bang in 1905 found that the most sensitive wavelengths were around 250 nm (Lorch 1987)
- Kuch in 1904 developed the first quartz lamp (Lorch 1987).
- Henri, Helbronner and Recklinghausen in 1910 put a UV system into the water supply for Marseille, France (Lorch 1987).
- Ignition of the lamps was a problem for the next 25 years.
- Advances in the production and use of chlorine gas after 1910 stopped the use of UV in North America.
- Westinghouse Electric first demonstrated the fluorescent gas discharge lamp in 1938.
- Lamps and ballasts were perfected in the 1940's, providing the resources for the future development of many of today's UV companies in North America and Europe.
- UV became an accepted process and it was widely used in Europe for disinfecting drinking water. Thousands of such UV systems are in operation today.
- In the late 1970's the USEPA began to discourage the use of chlorine for disinfecting wastewater and provided research money and construction grants for UV disinfection.
- In 1978, a full-scale innovative UV system was successfully demonstrated at the NW Bergen wastewater treatment plant, Waldwick, NJ (Scheible and Bassell 1981).
- In 1982 a modular UV system that fits in a gravity-fed, open channel with lamps parallel to the flow was introduced for the disinfection of wastewater (Whitby et al. 1984).

Most of the early UV systems that were installed were adapted from pressurized vessels that were used for disinfecting drinking water. Prompted by the relatively poor quality (low UV transmittance) and limited available hydraulic head typical of wastewater plants, new, and relatively small companies began to develop systems that would accommodate such specific characteristics associated with wastewaters. The rapid development of these various "first-generation" systems and their subsidized installation at full-scale facilities certainly helped to bring attention to UV but this also

created difficulties. Basic design flaws in most of these systems reflected poorly on the UV industry and raised cautions with government agencies, operators, and consultants.

The reasons that these earlier systems did not work reliably were:

- Replacement of lamps, quartz sleeves and ballasts required the shut down of the entire UV system.
- Cleaning systems failed to perform, and in some cases damaged the lamp battery upon mechanical failure.
- Poorly understood and inadequate hydraulics, whereby short-circuiting occurred and caused performance failures.
- Improper cooling of the ballasts, led to failure of the ballasts.
- Ballasts and UV lamps were not matched, leading to failure of the lamps.
- Difficulties in maintenance led to the failure of components such as Teflon® and/or quartz tubes, lamps, and ballasts.
- Lack of scientific information or protocols to adequately size a UV system for specific wastewater applications.

Most of these problems were eventually overcome. More rigorous attention to engineering design, fabrication quality, and the development of reliable lamp/ballast controls and configurations helped. Attention to understanding the hydraulic and water quality aspects of design moved the industry to its “second-generation” systems. These advanced open-channel, gravity flow, modular design concepts, soon convinced owners and regulators of UV’s reliability, and these systems began to dominate the wastewater disinfection market.

UV Design Advances – A Look Through Patent History

In 1972, US Patent 3634025 was issued to A. Landry for a UV system whereby water flowed by gravity through the inside of Teflon® tubes, and lamps surrounded the tube, as shown in Figure 1. The Teflon® was transparent to UV light and, in theory, suspended solids, oils and greases would not adhere to it. The UV system had very good hydraulics because of the long tubes and the many bends in the tubes. Studies showed, however, that as the Teflon® aged, it became worn and less transparent to the UV light (USEPA 1986). This system was very successful up until the middle of the 1980’s when it could not be scaled up for very large flows. It is still sold in Australia and was popular in the United Kingdom where coating of the quartz sleeves was a problem.

A US Patent 4103167 was issued to S. Ellner in 1978 for a UV system that used a large rectangular, gravity-flow chamber with lamps situated perpendicular to the flow (Figure 2). The UV system also used an in-place chemical cleaning system and UV sensors to determine the UV fluence. This UV system required 100 percent backup if a quartz sleeve had to be replaced or the quartz sleeves had to be cleaned. This was one of the first full-scale, gravity-flow UV systems of this size for wastewater within North America and it is still in use at the Suffern Wastewater Plant in Suffern, New York. A second US Patent 4767932 was issued to S. Ellner in August 1988 for a semi-pressurized (Figure 3a) and open-channel UV system (Figure 3b). The semi-pressurized, gravity flow UV system was installed in Madison, Wisconsin and treated over 50 mgd (8,000 m³/h), which was the largest UV system in the world at that time. The open-channel UV system with vertical lamps is still sold today.

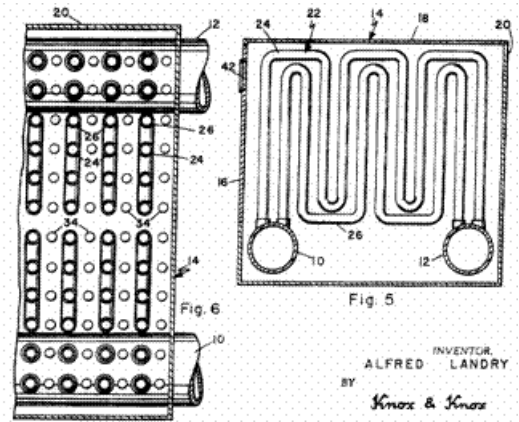

Figure 1. A Teflon® tube UV system for wastewater.

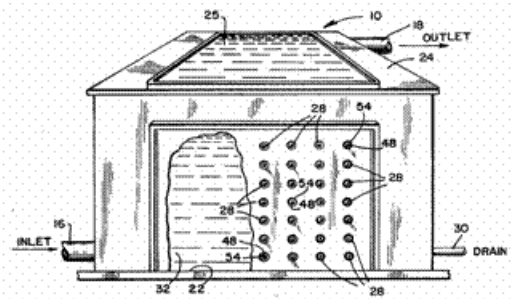

Figure 2. A semi-pressurized UV system where the UV lamps are perpendicular to the flow and the quartz sleeves are cleaned by circulating acid through the tank.

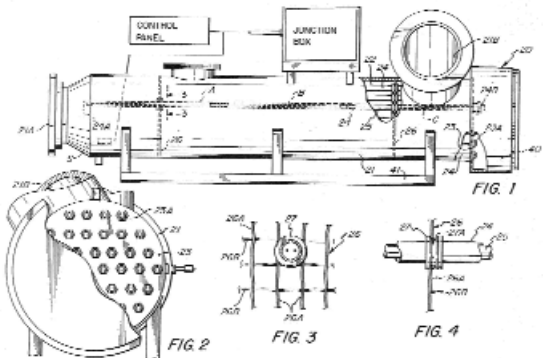

Figure 3. (a) A semi-pressurized gravity flow UV system; (b) An open channel UV system with vertical lamps.

A US Patent 4367410 was issued to M.D. Wood in 1983 for a gravity-flow, “thin-film,” open-channel UV system with a mechanical cleaning system, where the lamps were horizontal in the channel and perpendicular to the flow (Figure 4). The lamps in this UV system were very close together to overcome the problems with UV transmission. The system was first demonstrated at the NW Bergen Wastewater Treatment Plant (WWTP) in New Jersey (Scheible and Bassell 1981), and then again at the Port Richmond WWTP in New York (Scheible et al. 1983). These studies showed good performance, although the UV system was somewhat inefficient in its use of light. With the lamps perpendicular to the flow they tended to capture debris from the effluent, which would affect the cleaning system and put the wiper out of alignment and break lamps and quartz sleeves. The complete shutdown of the UV system was required to remove a quartz sleeve and this necessitated the need for 100 percent backup. Electrical difficulties plagued the system, primarily because of the lamp ends having to be positioned at the steel bulkheads holding the lamp/quartz assemblies, which caused overheating and premature failure of the electrodes. Although several full-scale systems were installed in the early 1980’s (e.g., Pella, IA and Northfield MN), the system configuration was eventually discontinued.

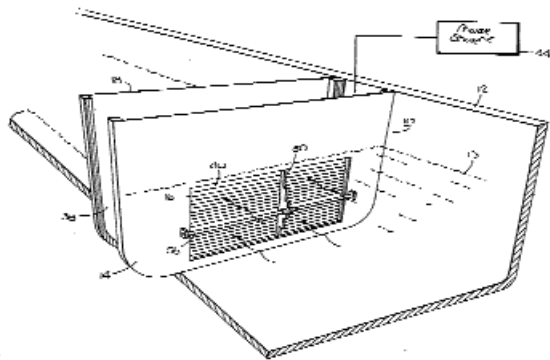

Figure 4. An open channel UV system where the UV lamps are perpendicular to the flow and the quartz sleeves are automatically cleaned.

A very important advancement in the development of effective UV equipment for disinfecting wastewater in North America was US Patent 4482809 in 1984 for a gravity-flow, open-channel, horizontal lamp, parallel-flow, modular UV system by J. Maarschalkerweerd (Figure 5). This UV system eliminated the need for pumps and could easily be retrofitted into an existing channel in a wastewater treatment plant (such as chlorine contact tanks and secondary effluent channels). The racks holding the lamps were modular so that each one could be removed individually for servicing while the rest of the UV system continued to function. This resulted in a lower cost UV system and made UV disinfection more cost-competitive with chlorination. The lamps were parallel to the flow so that debris only accumulated on the front and backs of the racks containing the lamps and not on the lamps themselves. The major difficulty with this UV system was if one seal or quartz sleeve broke all of the lamps in a single rack would be flooded out. This and similar UV

systems were improved in the late 1980’s by the addition of single ended quartz sleeves, reducing the number of seals by 50 percent. An improved sealing system that prevented all of the lamps in a rack from being flooded if one seal or quartz sleeve broke was granted to J. Maarschalkerweerd in 1989 as US Patent 4872980.

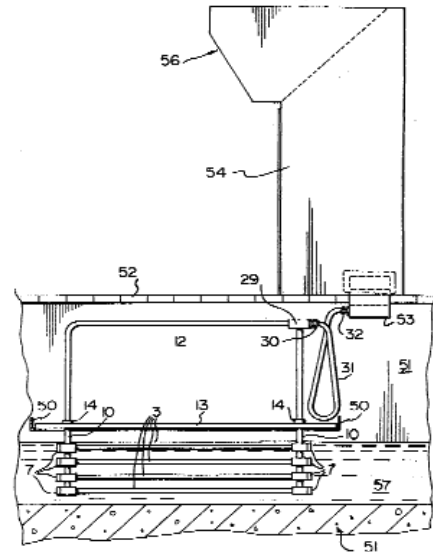

Figure 5. The open channel, parallel flow, horizontal lamp, modular UV system.

All of the previous designs of UV equipment for wastewater had problems associated with the cooling of the ballasts. The introduction of energy efficient electronic ballasts reduced the size of cabinets but it did not solve the problem of heat management. When fans were used to cool the ballasts; dust, insects and moisture were blown into the cabinets. When filters were added to the cabinets they were easily clogged and the ballasts overheated. A US Patent 4872980 was issued to J. Maarschalkerweerd in 1989 that described the incorporation of ballasts into the rack of the UV system (Figure 6) that had been described in US Patent 4482809 (Figure 5). This resolved, in large part, the difficulties with ballast cooling.

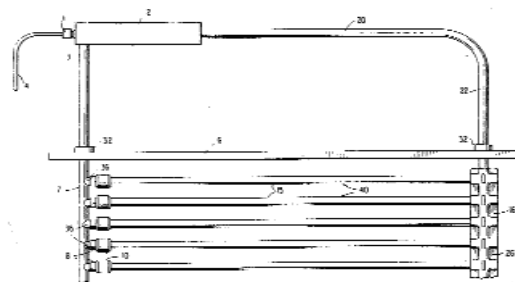

Figure 6. Open channel, parallel flow, horizontal lamp, modular UV system with the ballast incorporated in the rack for disinfecting fluids.

In hot climates, however, this system still required some form of sun protection and the ballasts were subject to moisture during flooding conditions due to the number of seals in the ballast enclosure. The solution to the cooling and moisture problems was the submerged

ballasts as described by H. Kozlowski in US Patent 6193939 in 2001. The use of this submerged ballast technology in an open-channel, parallel-flow UV system is shown in Figure 7.

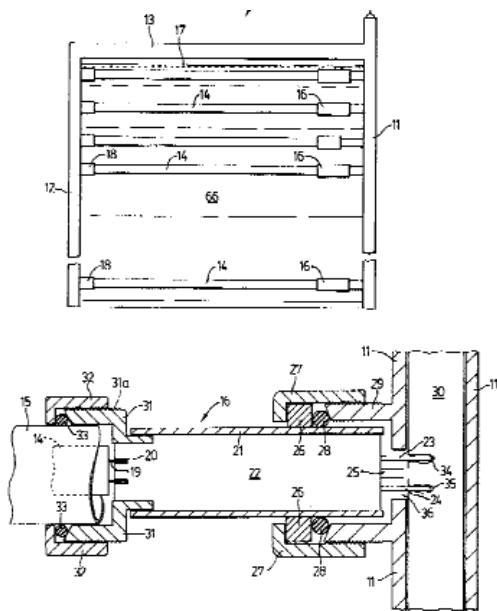

Figure 7. The use of a submerged ballast to eliminate the cooling and flooding problems associated with open-channel, parallel-flow UV systems.

Since then the open-channel, parallel-flow UV system has been improved by the use of higher output UV lamps and the incorporation of various cleaning systems.

In 1995 J. Maarschalkerweerd was granted US Patent 5418370 for a semi-pressurized UV system with medium-pressure lamps and automatic chemical and mechanical cleaning (Figure 8). The racks of UV lamps were moved in and out of a restriction in the channel; this eliminated the problem of controlling the level of the water over the lamps that was encountered in previous open-channel UV systems. The chemical and mechanical cleaning system was a stimulus in the market for UV systems with automatic cleaning. Virtually all the latest UV systems for wastewater are now sold with some form of automatic cleaning.

Cleaning Systems for UV Equipment

Von Recklinghausen noted that UV lamps were coated by compounds in the water in 1914. This prompted him to place the UV lamps out of the water. Since then cleaning of the quartz tubes around the lamps has been a major challenge. Inventors have come up with scrapers, brushes, ultrasonics, in-place acid cleaning, and chemicals along with scrapers. Unfortunately there are no independent scientific studies to show that any of these systems actually works better than another. Protocols have been constructed to verify a particular cleaning system's performance claims through the National Water Research Institute (NWRI 2003) and the EPA Environmental Technology Verification Program (USEPA 2003).

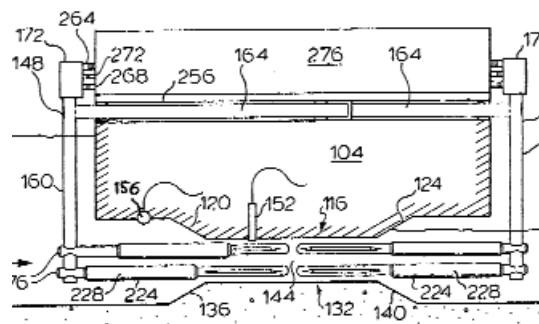

Figure 8. Semi-pressurized UV system with in-place chemical and mechanical cleaning.

Wipers and Scrapers: All of the patents on scrapers or wipers involve some form of felt, rubber, metal, plastic or Teflon[®] that is pushed or pulled down the length or around the circumference of a quartz tube. All of the patents describe different ways of carrying out this process.

The first reference to a scraper that the authors could find is in US Patent 1998076 issued to H.M. Creighton et al. in 1935 and is shown in Figure 9. The scraper (72) is pressed against a quartz sleeve and it is driven by a set of gears with the lamp in the centre (53).

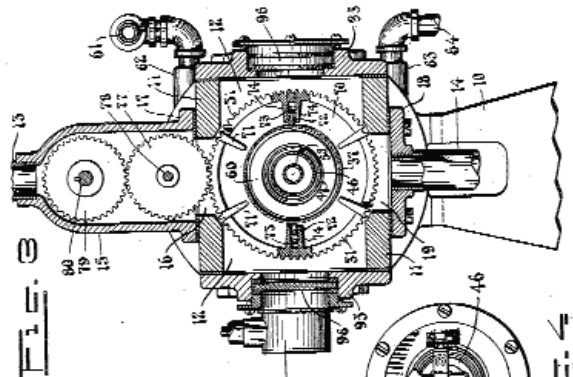

Figure 9. A UV system with a scraper (72) driven by a set of gears with the lamp in the centre (53).

As shown in Figure 4, M. D. Wood in US Patent 4367410 expanded on the idea of a wiper when he cleaned the entire UV array with one assembly. This system was not successful due to tolerance problems that resulted in breakage of the quartz sleeves. Modern UV systems have the array of lamps broken up into a number of individual modules or racks. Wipers using Teflon[®], rubber and metal are still used to clean quartz sleeves but these modules have their own independent wiping mechanisms. If one wiper fails it does not affect all of the other cleaning systems.

Ultrasonics: Patents have been issued for using ultrasonics for cleaning quartz sleeves in pressurized UV systems (R.M.G. Boucher US Patent 3672823, E.A. Pedziwiatr US Patent 4728368, and J.M. Maarschalkerweerd US Patent 5539209); semi-pressurized UV systems (S. Ellner US Patent 4358204); and UV probes (J.M. Maarschalkerweerd US Patent 5539210). Ultrasonic systems that were used to clean UV systems for wastewater were not effective (USEPA 1986).

Acid Cleaning: S. Ellner was issued US Patents 4103167, 4899056 and Re34513 in 1978, 1990, and 1994 respectively for using an acid to clean quartz sleeves either in-place with a recirculation system or after lifting the UV modules out of a channel. All of these methods required that the UV system be taken out of service. P. Binot was issued a US Patent in 1998 for using an acid and air injection system for cleaning a pressurized UV system.

Air Scouring: P. Schuerch et al. was issued a US Patent 5332388 in 1994 for an air scouring system for a vertical lamp UV system for disinfecting wastewater.

Chemical and Mechanical Cleaning: J.M. Maarschalkerweerd was issued US Patent 5418370 in 1995 for a chemical and mechanical method for cleaning the quartz sleeves in a semi-pressurized UV system. As shown in Figure 8 the quartz sleeve contracts into a sleeve and the acid inside the sleeve dissolves any minerals and the seals at the front of the sleeve scrape off any deposits. This cleaning system was modified so that the sleeve moved along the quartz sleeve.

E. Ishiyama invented a chemical and mechanical method for cleaning the quartz sleeves in an open channel parallel flow UV system with horizontal lamps as shown in Figure 10 and was issued US Patent 5874740 in 1999 (Figure 10). The acid cleaner is continually replenished.

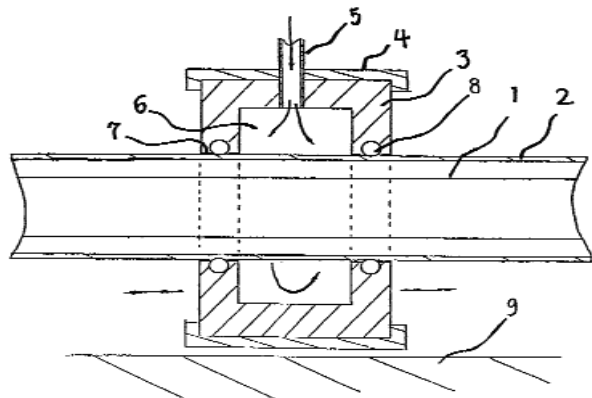

Figure 10. A chemical mechanical wiper system for cleaning the quartz sleeves in an open channel modular parallel flow UV system with horizontal lamps.

RESEARCH ON THE UV DISINFECTION OF WASTEWATER

This review cannot possibly cover all the papers on the UV disinfection of wastewater. Instead, the authors have selected some that pointed to new developments in understanding UV or advances in the design of UV systems. Annual reviews are published in the Journal “Water Research” by the Water Environment Federation, from which one can develop a more complete bibliography.

In 1975, Oliver and Carey hung a light fixture with UV lamps over the outfall of a tank of secondary effluent and showed that UV light could disinfect the effluent. They prepared a cost estimate on UV and concluded it was more expensive than chlorination but should be examined further. The effluent was not toxic to rainbow trout but

the chlorinated effluent was toxic (Oliver and Carey 1975). A second study by Oliver and Carey showed that the bacterial kill was independent of the UV intensity and that sonicating suspended solids increased the microbial kill. The research also showed that as the water depth increased, the fluence rate required to get a 2 log kill increased (Oliver and Carey 1976).

In 1977, Venosa et al. presented a paper on the ultraviolet disinfection of municipal effluent in Dallas Texas with a pressurized UV system (Venosa et al. 1977). An attenuated Type 1 strain of the polio virus and fecal coliforms were equally sensitive to UV light. The bacteriophage f2 was less sensitive to UV light. The authors concluded that UV light is a feasible disinfectant as long as the quality of the effluent is reasonably good. Dr. Albert Venosa of the USEPA became a strong proponent of UV disinfection and was instrumental in implementing USEPA-supported research and demonstration projects that advanced the industry’s understanding of the technology.

Three papers were presented at a conference in Cincinnati in 1978 on the UV disinfection of wastewater. A more detailed description of the above-cited pilot testing in Dallas, Texas was presented by Wolf et al. (1979). In parallel with the pressurized UV unit an open channel UV unit was used where the lamps hung over the water. The iso-intensity patterns of the UV intensity within the pressurized UV unit were described. This is one of the first descriptions of the UV intensity within a UV unit and an attempt to correlate the values with disinfection. A second paper by Johnson et al. (1979) introduced actinometry, residence time distributions and the concept of a bioassay to verify the fluence of a flow-through UV system. The bioassay approach became an important element in UV design, although controversy still surrounds its proper use and application to design practices. A third paper by Scheible and his coworkers (1979) showed the evaluation and costing for an open-channel UV system with a wiper and UV lamps perpendicular to the flow (Figure 4). This paper also presented information on how photoreactivation resulted in approximately a one-log increase in coliform density after UV exposure. The issue of photoreactivation has never been completely addressed in relation to what happens to the pathogens and its impact on disinfection performance.

Tonelli et al. (1978) published a very extensive review and a summary of research done by the Ontario Ministry of the Environment. This was the start of the Ontario Ministry of the Environment’s extensive involvement in the UV disinfection of wastewater.

The USEPA published its first large scale report on the UV disinfection of a municipal wastewater effluent in Dallas, Texas in August 1980 (Petrasek et al. 1980). All personnel associated with the project felt that UV was a viable disinfection process for secondary effluents. The UV system that had a shallow tray with lamps above the wastewater was not practical for large flows and it was susceptible to settling of the suspended solids. The full power of the lamps was not utilized. The authors found that suspended solids from 5 to 50 mg/L did not effect the UV transmission. UV light was very effective against the polio virus and the f2 coliphage

was a good indicator of the kill of viruses. UV systems with submerged lamps were more efficient than those with lamps out of the water. The authors felt that monitoring of the UV intensity was very important for process control. This is still one of the weakest points of UV disinfection. The researchers found that cleaning of the quartz sleeves was very important and that a schedule should be set-up so that the sleeves are kept clean. A nitrified effluent was easier to disinfect than a non-nitrified effluent and they felt that this was due to the increased quality of the effluent and UV transmission.

Severin (1980) looked at the UV disinfection of primary clarifier effluent, settled activated sludge effluent, activated sludge effluent with waste activated solids added, tertiary sand filtered effluent, mixed media filtration effluent, and trickling (roughing) filter effluent. The results showed that the effluents with the highest UV transmission and lowest solids had the greatest inactivation of the fecal coliforms. The author also proposed one of the first models for the UV disinfection of wastewater. Dye studies showed that decreasing the flow rate can lead to possible channelized flow within a UV reactor and this in conjunction with a non-uniform UV intensity profile can result in decreased inactivation rates. Even though this UV unit was meant for potable water the costs and operation indicated that the UV disinfection of wastewater was a viable alternative.

Ho and Bohm (1981) in Ontario, Canada showed that a UV unit that was used in fish hatcheries could meet a total coliform limit of 2500 per 100 mL even during plant upsets. The lamps in this unit were horizontal and perpendicular to the flow (Figure 11). The closed vessel used baffles along the top of the unit to prevent short circuiting. Several very extensive reports were published on the data (Ho 1982; Bohm 1982). This commitment of the Ontario Ministry of the Environment to UV disinfection of wastewater ultimately led to the extensive involvement of the Ministry in the full scale UV testing at the wastewater treatment plant in Tillsonburg, Ontario that began in February 1982 (Whitby et al. 1984). A final report was issued by Ho and Bohm in 1984. This report showed photoreactivation of the total coliforms of approximately 0.6 logs after six hours of artificial sunlight. Ho and Bohm looked at the reduction in T-bacteriophages and they went from 40 to 300 per 100 mL to a geometric mean of 2 per 100 mL. Mixtures of 4, 10 and 20 percent primary effluent with secondary effluent were disinfected to less than 1000 total coliforms per 100 mL. The UV transmission was 28.5 percent and the suspended solids were 48.7 mg/L with a 20 percent addition of primary effluent.

The USEPA published work conducted at the NW Bergen WWTP in New Jersey (Scheible and Bassell 1981). This was the first extensive large-scale testing of a UV system that was designed for wastewater. The UV unit used the "thin film" configuration cited earlier, and was designed to treat up to 30,000 m³/day and had 400 UV lamps. The study looked at cost, photoreactivation, effluent quality, calculation of UV dose, operation and maintenance, and sizing of UV systems.

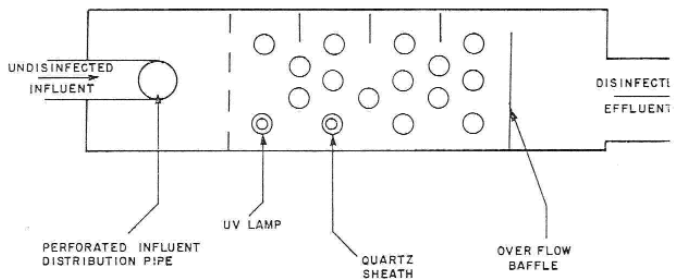

Figure 11. The UV system used by Ho and Bohm showing the baffles to prevent short circuiting along the top surface of the UV unit.

In 1981 the USEPA published the extensive work of Johnson and Qualls on the use of a bioassay, collimated beam, and tracer studies for characterizing a flow through UV system and this was followed up by other studies by the authors on the same subjects (Qualls and Johnson 1983; Johnson et al. 1981; Qualls and Johnson 1985). The design of the collimated beam has been the basis of all subsequent units. This bioassay used *Bacillus subtilis*. A method was developed to account for the scattering of UV light by suspended solids in a spectrophotometer. The authors also looked at the effect of suspended solids on the log survival of the total coliforms and showed that the solids protect the microorganisms (Qualls et al. 1983). In 1989 Qualls et al. followed this up with another study of a flow-through UV system using a bioassay and tracers to characterize the hydraulics.

A review of the UV disinfection of wastewater by Albert Venosa in the Journal of the Water Pollution Control Federation in 1983 showed that there were still a lot of unanswered questions but UV was an acceptable alternative to chlorine. These questions were:

- What are the effects of suspended solids and UV transmission?
- What is the optimum system size and configuration?
- Can UV disinfect combined sewer overflow (CSO)?
- What is the best cleaning method?
- What is the best method to measure UV dose?
- Should photoreactivation be accounted for?

Most of these questions are still being debated today.

Severin et al. (1983, 1984a, 1984b) proposed a series event model to describe the behavior of microorganisms in a batch and a flow through completely mixed reactor.

In 1984 Whitby et al. published their long-term, side-by-side comparison of chlorination and a full-scale, open channel UV system with horizontal lamps that are parallel to the flow. This study looked at the coliforms, fecal streptococci, *Clostridium perfringens*, *Pseudomonas aeruginosa*, and bacteriophage to *Escherichia coli* C. The study reported that UV disinfection was as cost effective as chlorination, the effluent disinfected with UV light was not toxic to Rainbow trout, and UV disinfection was as effective as chlorination in eliminating bacteria but more effective with bacteriophages and therefore more likely to inactivate human viruses. There was a one-

log increase in the coliforms after photoreactivation but a follow-up study showed that in the receiving stream no photoreactivation could be detected (Whitby et al. 1985). This follow-up study also showed that the UV output of the lamps after one year was below 65% but the curve flattened out for another year.

Scheible et al. (1983) published the findings of a major large-scale pilot study at New York City's Port Richmond WWTP. Three large scale systems were specified and each one was capable of treating up to 1 mgd of secondary effluent or CSO. This major research and demonstration project focused on the development of a rational design protocol for the UV process, incorporating the hydraulic characteristics of a system, the calculation of the intensity in a complex reactor, and the effect of wastewater quality. The study quantified the effect of suspended solids on system performance, related inactivation kinetics to system intensity, and reported on the ability of UV to disinfect CSO-type wastewaters.

A survey by White et al. (1986) identified 52 UV systems that were operating in Canada and the United States. Inspections of six of the systems showed that most of the problems were electrical, mechanical and hydraulic and not due to the UV process itself. The authors recommended that designers become more involved in the design of the UV equipment and its installation. This was one of the objectives of the USEPA Design Manual Municipal Wastewater Disinfection.

In October 1986 the USEPA published the Design Manual: Municipal Wastewater Disinfection (USEPA 1986). This was the first major design publication that gave UV equal footing to chlorination and other alternatives. Chapter 7, authored by Karl Scheible, was devoted to ultraviolet disinfection, and represented the outcome of several years of research and demonstration projects conducted by Scheible and others. (Scheible et al. 1983; Scheible and Bassell 1981; Scheible 1985; Scheible et al. 1979). It is an excellent review of all the UV knowledge with regard to wastewater at that time and presents the findings of very extensive UV pilot testing. This chapter was written with the idea that it would give the person designing a wastewater treatment plant the knowledge of how to specify the number of lamps in a UV unit and how to install the UV unit. It addressed critical considerations with respect to hydraulic design, wastewater characteristics, the importance of UV transmittance, and the impact of particles on ultimate performance levels. Much of the discussion contained in the Design Manual is still relevant to today's design problems.

The USEPA Design Manual reported a UV process design (Scheible et al. 1986) developed from the Port Richmond pilot studies that took into account the UV equipment and its hydraulics, flow, UV transmission, suspended solids, influent and effluent indicator organisms. This model, embodied in the UVDIS software developed by HydroQual, Mawah, NJ is used by many major UV companies around the world to size UV equipment. The model also showed when the disinfection limit could not be met. When this model is being used it is important to remember that the coefficients are supposed to be developed with data from the wastewater treatment plant where the equipment is being installed.

Throughout the 1980's and 90's Arie Havelaar in collaboration with other scientists (Nieuwstad and Havelaar 1994; Sommer et al. 1995; Havelaar et al. 1991; Havelaar and Hogeboom 1984; Nieuwstad et al. 1991; Mooijman et al. 2001; Havelaar et al. 1987; Havelaar et al. 1990; Havelaar 1993; Havelaar and IAWPRC Study Group on Health Related Water Microbiology 1991) started working with F-specific coliphages in wastewater before and after UV disinfection as a model for human pathogenic viruses. Havelaar and his co-workers also showed that the MS2 coliphage could be used to measure the UV fluence in batch and flow-through reactors with low and medium pressure lamps. This work led to the adoption of the MS2 coliphage for bioassays of UV equipment for water and wastewater in North America, supplanting the common use of spores of *B. subtilis*.

In 1991 Snider et al. showed that UV disinfection could be used to meet the California Title 22 requirement of 2.2 total coliforms per 100 mL. This opened up an entirely new market for UV equipment in wastewater treatment plants. It also broadened the entire controversy over how to do a bioassay and qualify for California Title 22. This resulted in the publication of "UV Disinfection Guidelines for Wastewater Reclamation in California and UV Disinfection Research Needs Identification" in 1993 by the National Water Research Institute. This document was followed up in 2000 and 2003 by a joint effort between the National Water Research Institute and American Waterworks Association Research Foundation to address new equipment and the use of a bioassay to determine the UV fluence. The document also defined as many of the UV terms as possible.

In 1992 a survey was published of the UV systems in wastewater treatment plants in North America by the US EPA (Scheible et al. 1992). The report recommended that additional information should be collected on how to design UV systems for alternate indicator organisms such as *E. coli* and enterococci. It recommended the use of the open-channel, modular, gravity flow UV systems. The authors recommended that more research be done on the use of high intensity lamps. More research should be done on photoreactivation but it should be done in comparison to chlorination/dechlorination.

The Water Environment Research Foundation (WERF) published a comparison between UV irradiation and chlorination along with a new model to size UV systems (Darby et al. 1995). This model has not seen widespread use but the authors felt that it better represented UV disinfection when it was being used for water reuse.

Although the effects of particles had been studied in the 1980's, Jeannie Darby's research group extended this work in the 1990's by looking at what upstream processes effect the presence of indicator organisms in and on particles (Loge et al. 2002; Darby et al. 1999; Loge et al. 2001; Parker and Darby 1995; Loge et al. 1997; Emerick et al. 1998; Loge et al. 1999; Emerick et al. 1999; Emerick et al. 1999a; and Emerick et al. 2000). The upstream processes are very important if the effluent must meet the standards for water reuse. The report has guidelines for selecting the upstream processes that match the UV system to the disinfection limit. They also did more research on the effect of particle size. It is becoming a routine practice to do particle sizing on a wastewater during the design

phase of a UV system. The research showed that the longer a particle remains in a wastewater treatment plant the fewer coliforms are associated with it.

A major demonstration project was reported on the application of alternative UV technologies for primary and secondary effluents (Scheible 1999). Five large-scale UV systems (0.5 to 1.5 mgd) were installed and operated with secondary and primary effluents. These systems included advanced low-pressure high-output and medium-pressure lamp systems, and a benchmark conventional lamp system. Performance was evaluated over a range of hydraulic loadings, and monitored via fecal coliform, total suspended solids (TSS), and transmittance analyses. The USEPA UV disinfection model was calibrated with the data, and used to size the various configurations for alternative wastewater applications. Costs were generated, which formed the basis for a subsequent WERF analysis of costs versus chlorination/dechlorination. The study further developed the impact of suspended solids on disinfection performance. Subsequent efforts (Scheible 1999a) were directed to raw wastewaters that were drawn after the plant bar screens and fed to a continuous-deflection (CDS) screen, with 1200- and 600-micron apertures, for TSS and trash removals. A fuzzy filter (FF) was placed downstream of the CDS; this fiber-based media filter was found to effectively remove TSS at particle sizes greater than 50-micron, which is similar to that of primary sedimentation. Three different high-output UV systems were tested downstream of the CDS with and without fuzzy-filter pretreatment. Collimated beam measurements on fractionated samples demonstrated that dose improvements beyond that accomplished with FF filtration would require TSS removals to less than 1 micron. Fecal coliform reductions of 2 to 3 logs were demonstrated with UV after removal of gross TSS.

Bioassays (or biosimetry) have been developed as a standard method to quantify the fluence delivered by a UV reactor, and they rely primarily on MS2 coliphage as the challenge organism (Scheible 2000; HydroQual and NSF International 2002). The NWR/AwwaRF guidance for UV disinfection of reuse and drinking waters present protocols for such tests, and the USEPA Environmental Technology Verification program has protocols for reuse, secondary effluent and wet weather flow applications. Extensive work has been reported on the use of such methods in the USEPA's draft UV Design Guidance Manual (USEPA 2003). Alternative challenge organisms are also being investigated that more closely represent the UV sensitivity of targeted organisms. Facilities have been established worldwide to provide such testing for full-scale commercial UV reactors.

A bioassay only provides the average values of the UV fluence of a flow through UV system. The studies with a hydraulic tracer do not give any indication of how or where short circuiting may be taking place. Ernest Blatchley and his co-workers (Do-Quang et al. 1997; Lyn et al. 1997; Blatchley 1998a; Chiu et al. 1999a; Lyn et al. 1999a; Chiu et al. 1999b; Chiu et al. 1998; Blatchley et al. 1998; Blatchley 2000; Lin and Blatchley 2001; Lyn et al. 1999; Lyn et al. 1999b; Blatchley 1997; Blatchley et al. 1993; Blatchley 1998b; Blatchley et al. 1994; Lin and Blatchley 2000) established an

alternative to the bioassay and tracer studies by using computational fluid dynamics (CFD). When combined with fluence-rate models within a reactor, CFD has allowed UV companies, researchers and designers of wastewater treatment plants to get a better understanding of the dose-distribution within a UV system. CFD is being embraced for drinking water applications. The modeling approach allows a UV system to be optimized before it is built. When combined with biosimetry, it becomes a powerful tool for verifying the performance of a reactor over its operating range. CFD and dose-distribution modeling have not been fully accepted, largely due to the newness of the technique, and to the uncertainties surrounding calibration and validation of such modeling approaches.

A survey in 2003 by the Water Environment Federation showed that of all the respondents 24 percent used UV disinfection in their wastewater treatment plants and 66 percent were planning to switch to UV (Water Environment Federation 2004). There are approximately 18,000 wastewater treatment plants in North America and there could be at least 4,000 UV systems. UV disinfection of wastewater is an accepted disinfection technique for wastewater. Its application to CSO and Sanitary Sewer Overflow (SSO) type wastewaters has been successfully demonstrated as well as water reuse. More work needs to be done to understand the limits of UV when it is used for such high level disinfection as water reuse, including the need for effective upstream processes and rigorous maintenance of the UV equipment.

Biosimetry is an effective tool in quantifying and validating the performance of a system. Although there are protocols for such testing, an effort needs to be made to apply these on a consistent basis, a role that can be played by the regulatory community. Biosimetry and CFD-based dose-distribution modeling should be expanded for use in wastewater applications, addressing dose requirements and the proper selection of challenge organisms to validate various performance levels. Standard protocols are needed for determining the UV output of a lamp, and, in particular the end of lamp life output.

Effective O&M is critical to the successful application of UV to wastewaters. A survey should be taken of UV systems in wastewater and water treatment plants to determine their strengths and weaknesses, and to define effective procedures for preventative maintenance. This is all the more important as UV is used in more plants that are producing water for reuse.

REFERENCES

- Blatchley, E.R. 1997. Numerical Modeling of UV Intensity: Application to Collimated-Beam Reactors and Continuous-Flow Systems. *Wat. Res.* 31(9): 2205–2218.
- Blatchley, E.R. 1998a. Comment on “Numerical Modeling of UV Intensity: Application to Collimated-Beam Reactors and Continuous-Flow Systems”. *Wat. Res.* 32(7): 2240–2242.
- Blatchley, E.R. 1998b. Modeling Tools for Use in the Design of Ultraviolet Disinfection Systems. *Ultraviolet Disinfection The Pros and Cons: What You Need to Make it Work – Pre Conference Workshop – WEFTEC '98*. Water Environment Federation, Alexandria, VA, USA.

- Blatchley, E.R. 2000. Process Dynamics in UV Disinfection. American Water Works Association, 2000 Water Quality Technology Conference. AWWA, Denver, Colorado, USA.
- Blatchley, E.R., Bastian, K.C., Duggirala, R., Hunt, B.A., Alleman, J.E., Wood, W.L., Moore, M., Anderson, B.L., Gasvoda, M., and Schuerch, P. 1993. Large-Scale Pilot Investigation of Ultraviolet Disinfection. Planning, Design & Operations of Effluent Disinfection Systems – Specialty Conference. Water Environment Federation, Alexandria, VA, USA.
- Blatchley, E.R., Do-Quang, Z., Janex, M.-L., and Laîné, J.-M. 1998. Process Modeling of Ultraviolet Disinfection. *Wat. Sci. Technol.* 38(6): 63–69.
- Blatchley E.R., Duggirala, R., Chiu, K., Noesen, M., Jaques, R., and Schuerch, P. 1994. Macro-Scale Hydraulic Behavior in Open Channel UV Disinfection Systems. 67th Annual Conference & Exposition – WEFTEC '94, Water Environment Federation, Alexandria, VA, USA.
- Bohm, P. 1982. Application of UV Disinfection Technology in Ontario WPCP Effluents. Progress Report by the Ontario Ministry of the Environment, Toronto, Ontario, Canada.
- Chiu, K., Lyn, D.A., and Blatchley, E.R. 1998. Measurements and Modeling of Microscale Hydrodynamic Behavior in UV Disinfection Systems: Application for Improvement of Process Performance. Disinfection '98 – The Latest Trends in Wastewater Disinfection: Chlorination vs. UV Disinfection. p. 35–45. Water Environment Federation, Alexandria, VA, USA.
- Chiu, K., Lyn, D.A., Savoye, P., and Blatchley, E.R. 1999a. Integrated UV Disinfection Model Based on Particle Tracking. *J. Environ. Engrg.* 125(1): 7–16.
- Chiu, K., Lyn, D.A., Savoye, P., and Blatchley E.R. 1999b. Effect of UV System Modifications on Disinfection Performance. *J. Environ. Engrg.* 125(5): 459–469.
- Darby, J., Emerick, R., Loge, F., and Tchobanoglous, G. 1999. The Effect of Upstream Treatment Processes on UV Disinfection Performance. Water Environment Research Foundation, Alexandria, VA, USA.
- Darby, J., Heath, M., Jacangelo, J., Loge, F., Swain, P., and Tchobanoglous, G. 1995. Comparison of UV Irradiation to Chlorination: Guidance for Achieving Optimal UV Performance. Water Environment Research Foundation, Alexandria, VA, USA.
- Do-Quang, Z., Djebbar, R., Blatchley, E.R., and Laîné, J. 1997. Computational Fluid Dynamics (CFD) Modeling of UV Disinfection Reactor Performances: Optimization of the Flow in Vertical Lamps Open Channel. CSCE/ASCE Environmental Engineering Conference, Edmonton, AB, Canada.
- Downes, A. and Blunt, T.P. 1878–1879. On the Influence of Light upon Protoplasm. *Proc. Royal Soc. (London)* 18: 199–212.
- Emerick, R.W., Loge, F., Williams, C., and Darby, J.L. 1998. Impact of Particles with Embedded Coliform Bacteria on UV Disinfection. 71st Annual Conference & Exposition – WEFTEC '98. Water Environment Federation, Alexandria, VA, USA.
- Emerick, R.W., Loge, F., Williams, C., and Darby, J.L. 1999. Modeling the Inactivation of Particle Associated Coliform Bacteria by UV Light. 72nd Annual Conference & Exposition – WEFTEC '99. Water Environment Federation, Alexandria, VA, USA.
- Emerick, R.W., Loge, F.J., Ginn, T., and Darby, J.L. 2000. Modeling the Inactivation of Particle-Associated Coliform Bacteria. *Wat. Environ. Res.* 72(4): 432–438.
- Emerick, R.W., Loge, F.J., Thompson, D.E., and Darby, J.L. 1999a. Factors Influencing Ultraviolet Disinfection Performance Part II: Association of Coliform Bacteria with Wastewater Particles. *Wat. Environ. Res.* 71(6): 1178–1187.
- Environment Canada 1978. Wastewater Disinfection in Canada. EPS 3-WP-78-4, Environmental Protection Service, Canada.
- Havelaar, A.H. 1993. Bacteriophages as Models of Human Enteric Viruses in the Environment. *ASM News* 59(12): 614–619.
- Havelaar, A.H. and Hogeboom, W.M. 1984. A Method for the Enumeration of Male-Specific Bacteriophages in Sewage. *J. Appl. Bacteriol.* 56: 439–447.
- Havelaar, A.H. and IAWPRC Study Group on Health Related Water Microbiology 1991. Bacteriophages as Model Viruses in Water Quality Control. *Wat. Res.* 25(5): 529–545.
- Havelaar, A.H., Meulemans, C.C.E., Pot-Hogeboom, W.M., and Koster, J. 1990. Inactivation of Bacteriophage MS2 in Wastewater Effluent with Monochromatic and Polychromatic Ultraviolet Light. *Wat. Res.* 24(11): 1387–1393.
- Havelaar, A.H., Nieuwstad, T.J., Meulemans, C.C.E., and van Olphen, M. 1991. F-Specific RNA Bacteriophages as Model Viruses in UV Disinfection of Wastewater. *Wat. Sci. Technol.* 34(2): 347–352.
- Havelaar, A.H., Pot-Hogeboom, W.M., Koot, W., and Pot, R. 1987. F-Specific Bacteriophages as Indicators of the Disinfection Efficiency of Secondary Effluent with Ultraviolet Radiation. *Ozone Sci. Engrg.* 9: 353–368.
- Ho, K W A. 1982. Application of Ultraviolet Disinfection in a Tertiary Wastewater Treatment Plant. Research Report #87, Ontario Ministry of the Environment, Toronto, Ontario, Canada.
- Ho, K.W.A. and Bohm, P. 1981. UV Disinfection of Tertiary and Secondary Effluents. *Wat. Pollut. Res. J. Canada* 16: 33–44.
- Ho, K.W.A. and Bohm, P. 1984. Evaluation of Ultraviolet Light Disinfection Process in Richmond Hill Secondary WPCP. Ontario Ministry of the Environment, Toronto, Ontario, Canada.
- HydroQual and NSF International 2002.. Verification Protocol for Secondary Effluent and Water Reuse Disinfection Applications. 40CFR35.6450. Prepared for the USEPA ETV Program under NSF International, Ann Arbor, MI.
- Johnson, J.D., Aldrich, K., Francisco, D.E., Wolff, T., and Elliott, M. 1979. UV Disinfection of Secondary Effluent. Progress in Wastewater Disinfection Technology – Proceedings of the National Symposium, pp. 108–116, United States Environmental Protection Agency, Cincinnati, OH, USA.
- Johnson, J.D., Qualls, R.G., and Venosa, A.D. 1981. Ultraviolet Disinfection of a Secondary Effluent – Calculation and Measurement of Dose and Effect of Filtration. United States Environmental Protection Agency, Cincinnati, OH, USA.
- Lin, L.S. and Blatchley, E.R. 2001. UV Dose Distribution Characterization Using Fractal Concepts for System Performance Evaluation. *Wat. Sci. Technol.* 43(11): 181–188.
- Lin, L. and Blatchley, E.R. 2000. Process Modeling and Design of UV-Based Systems Using a Statistical Approach. Disinfection 2000: Disinfection of Wastes in the New Millennium. Water Environment Federation, Alexandria, VA, USA.
- Loge, F., Emerick, R., Williams, C., Kido, W., and Darby, J. 1997. Impact of Particle Associated Coliform on UV Disinfection. 70th Annual Conference & Exposition – WEFTEC '97. Water Environment Federation, Alexandria, VA, USA.
- Loge, F.J., Bourgeois, K., Emerick, R.W., and Darby, J.L. 2001. Variations in Wastewater Quality Parameters Influencing UV Disinfection Performance: Relative Impact of Filtration. *J. Environ. Engrg.* 127(9): 832–837.

- Loge, F.J., Emerick, R.W., Ginn, T.R., and Darby, J.L. 2002. Association of Coliform Bacteria with Wastewater Particles: Impact of Operational Parameters of the Activated Sludge Process. *Wat. Res.* 36(1): 41–48.
- Loge, F.J., Emerick, R.W., Thompson, D.E., Nelson, D.C., and Darby, J.L. 1999. Factors Influencing Ultraviolet Disinfection Performance Part I: Light Penetration to Wastewater Particles. *Wat. Environ. Res.* 71(3): 377–381.
- Lorch, W. 1987. *Handbook of Water Purification* 2nd Edition. Ellis Horwood Limited, Chichester, United Kingdom.
- Lyn, D.A., Chiu, K., and Blatchley, E.R. 1999. Numerical Modeling of Flow and Disinfection in UV Disinfection Channels. *J. Environ. Engrg.* 125(1): 17–26.
- Lyn, D.A., Chiu, K., and Blatchley, E.R. 1997. Flow Characteristics in Ultraviolet Disinfection Channels: An Evaluation of Numerical Predictions. CSCE/ASCE Environmental Engineering Conference, Edmonton, AB, Canada.
- Lyn, D.A., Chiu, K., and Blatchley III, E.R. 1999a. Numerical Modeling of Flow and Disinfection in UV Disinfection Channels. *J. Environ. Engrg.* 125(1): 19–26.
- Lyn, D.A., Chiu, K., Savoye, P., and Blatchley III, E.R. 1999b. Integrated UV Disinfection Model Based on Particle Tracking. *J. Environ. Engrg.* 125(1): 7–16.
- Mooijman, K.A., Bahar, M., Contreras, N., and Havelaar, A.H. 2001. Optimization of the ISO-Method on Enumeration of Somatic Coliphages (Draft ISO 10705-2). *Wat. Sci. Technol.* 43(12): 205–208.
- National Water Research Institute (NWRI) 1993. UV Disinfection Guidelines for Wastewater Reclamation in California and UV Disinfection Research Needs Identification. NWRI, Fountain Valley, CA, USA.
- National Water Research Institute (NWRI) and the American Water Works Research Foundation (AWWARF) 2000. Ultraviolet Disinfection Guidelines for Drinking Water and Water Reuse, 1st Ed., NWRI-2003-06, NWRI, Fountain Valley, CA, USA.
- National Water Research Institute (NWRI) and the American Water Works Research Foundation (AWWAFR) 2003. Ultraviolet Disinfection Guidelines for Drinking Water and Water Reuse, 2nd Ed., NWRI-2003-06, NWRI, Fountain Valley, CA, USA.
- Nieuwstad, T.J. and Havelaar, A.H. 1994. The Kinetics of Batch Ultraviolet Inactivation of Bacteriophage MS2 and Microbiological Calibration of an Ultraviolet Pilot Plant. *J. Environ. Sci. Health A29(9)*: 1993–2007.
- Nieuwstad, T.J., Havelaar, A.H., and van Olphen, M. 1991. Hydraulic and Microbiological Characterization of Reactors for Ultraviolet Disinfection of Secondary Wastewater Effluent. *Wat. Res.* 25(7): 775–783.
- Oliver, B.G. and Carey, J.H. 1975. A Scale-Up Investigation of Ultraviolet Disinfection as an Alternative to Chlorination for Sewage Effluents. *Can. J. Chem. Engrg.* 53: 711–712.
- Oliver, B.G. and Carey, J.H. 1976. Ultraviolet Disinfection: An Alternative to Chlorination. *J. Wat. Pollut. Contl. Fed.* 48(11): 2619–2624.
- Parker, J.A. and Darby, J.L. 1995. Particle-Associated Coliform in Secondary Effluents: Shielding from Ultraviolet Light Disinfection. *Wat. Environ. Res.* 67(7): 1065–1075.
- Petrasek, A.C., Wolf, H.W., Esmond, S.E., and Andrews, D.C. 1980. Ultraviolet Disinfection of Municipal Wastewater Effluents. EPA-600/2-80-102 United States Environmental Protection Agency, Cincinnati, OH, USA.
- Qualls, R.G., Dorfman, M.H., and Johnson, J.D. 1989. Evaluation of the Efficiency of Ultraviolet Disinfection Systems. *Wat. Res.* 23(3): 317–325.
- Qualls, R.G., Flynn, M.P., and Johnson, J.D. 1983. The Role of Suspended Particles in Ultraviolet Disinfection. *J. Wat. Pollut. Contl. Fed.* 55(10): 1280–1285.
- Qualls, R.G. and Johnson, J.D. 1983. Bioassay and Dose Measurement in UV Disinfection. *Appl. Environ. Microbiol.* 42(3): 872–877.
- Qualls, R.G. and Johnson, J.D. 1985. Modeling and Efficiency of Ultraviolet Disinfection Systems. *Wat. Res.* 19(8): 1039–1046.
- Riordan, C. 1979. Perspectives on Wastewater Disinfection – A View from Headquarters. *Progress in Wastewater Disinfection Technology, Proceedings of the National Symposium EPA-600/9-79-018*, United States Environmental Protection Agency, Cincinnati, OH, USA.
- Scheible, O.K. 1985. Development of a Rationally Based Design Protocol for the Ultraviolet Light Disinfection Process. 58th Annual WPCF National Conference. Water Pollution Control Federation, Alexandria, VA, USA.
- Scheible, O.K. 1999. Evaluation of Disinfection Technologies: Application of Alternative UV Technologies to Primary and Secondary Effluents: Rockland County Sewer District No. 1. NYS Energy Research and Development Authority, Final Report 99-8, Albany, NY, October 1999.
- Scheible, O.K. 1999a. CDS, Fuzzy Filter, and UV Treatment of SSO-Type Wastewaters. NYS Energy Research and Development Authority, Final Report 99-8, Albany, NY, October 1999.
- Scheible, O.K. 2000. Will This UV System Really Work? *Wat. Environ. Technol.* 12(10): 22–26.
- Scheible, O.K. and Bassell, C.D. 1981. Ultraviolet Disinfection of a Secondary Wastewater Treatment Plant Effluent EPA-600/S2-B1-152. United States Environmental Protection Agency, Cincinnati, OH, USA.
- Scheible, O.K., Binkowski, G., and Mulligan, T.J. 1979. Full Scale Evaluation of Ultraviolet Disinfection of a Secondary Effluent. *Progress in Wastewater Disinfection Technology – Proceedings of the National Symposium EPA-600-79-018*. United States Environmental Protection Agency, Cincinnati, OH, USA.
- Scheible, O.K., Casey, M.C., and Forndran, A. 1996. Ultraviolet Disinfection of Wastewaters from Secondary Effluent and Combined Sewer Overflows. EPA-600/2-86/005, NTIS No. PB86-145182, US Environmental Protection Agency, Cincinnati, OH.
- Scheible, O.K., Forndran, A., and Leo, W.M. 1983. Pilot Investigation of Ultraviolet Wastewater Disinfection at the New York City Port Richmond Plant. *Proceedings of the Second National Symposium on Municipal Wastewater Disinfection*. United States Environmental Protection Agency, Cincinnati, Ohio, USA.
- Scheible, O.K., Gupta, A., Scannel, D., and Bell, W. 1992. Ultraviolet Disinfection Technology Assessment, EPA 832-R-92-004. United States Environmental Protection Agency, Washington, DC, USA.

- Severin, B.F. 1980. Disinfection of Municipal Wastewater Effluents with Ultraviolet Light. *J. Wat. Pollut. Contl. Fed.* 52(7): 2007–2018.
- Severin, B.F., Suidan, M.T., and Engelbrecht, R.S. 1983. Kinetic Modeling of UV Disinfection of Water. *Wat. Res.* 17(11): 1669–1678.
- Severin, B.F., Suidan, M.T., and Engelbrecht, R.S. 1984a. Mixing Effects in UV Disinfection. *J. Wat. Pollut. Contl. Fed.* 56(7): 881–888.
- Severin, B.F., Suidan, M.T., Rittmann, B.E., and Engelbrecht, R.S. 1984b. Inactivation Kinetics in a Flow-Through UV Reactor. *J. Wat. Pollut. Contl. Fed.* 56(2): 164–169.
- Snider, K.E., Darby, J.L., and Tchobanoglous, G. 1991. Evaluation of Ultraviolet Disinfection for Wastewater Reuse Applications in California. University of California Davis, Davis, CA, USA.
- Sommer, R., Cabaj, A., Schoenen, D., Gebel, J., Kolch, A., Havelaar, A.H., and Schets, F.M. 1995. Comparison of Three Laboratory Devices for UV-Inactivation of Microorganisms. *Wat. Sci. Technol.* 31(5–6): 147–156.
- Tonelli, F.A., Duff, R., and Wilcox, B. 1978. Ultraviolet Disinfection of Domestic Sewage and Stormwater – A Literature Evaluation. Ontario Ministry of the Environment, Toronto, Ontario, Canada.
- USEPA 1976. Disinfection of Wastewater – Task Force Report. EPA-430/9-75-013, US Environmental Protection Agency, Washington, DC.
- USEPA 1986. Design Manual – Municipal Wastewater Disinfection. EPA/625/1-86/021 United States Environmental Protection Agency, Cincinnati, OH, USA.
- USEPA, 2003. UV Design Guidance Manual (Draft), USEPA Office of Drinking Water, Washington, DC, USA.
- Venosa A.D., Wolf, H.W., and Petrasek, A.C. 1977. Ultraviolet Disinfection of Municipal Effluents. Volume 2, 675–684. Ann Arbor Science, Ann Arbor, Michigan, USA. In: Jolley, R.L., Gorchev, H., and Hamilton, D. H. *Water Chlorination Environmental Impact and Health Effects.*
- Venosa, A.D. 1983. Current State-of-the-Art of Wastewater Disinfection. *J. Wat. Pollut. Contl. Fed.* 55(5): 457–466.
- Von Recklinghausen, M. 1914. The Ultra-Violet Rays and their Application for the Sterilization of Water. *J. Franklin Inst.* (1057-1062): 681–704.
- Water Environment Federation 2004. Water Environment Federation Disinfection Process Survey Summary. *Wat. Environ. Technol.* 16(7): 47 and 49.
- Whitby, G.E., Palmateer, G., Cook, W. G., Boon, F., and Janzen, E. 1985. The Effects of Wastewater Quality on Ultraviolet Light Disinfection. Proceedings of Technology Transfer Conference No. 6, Part 2 Water Quality Research. Ontario Ministry of Environment, Toronto, Ontario, Canada.
- Whitby, G.E., Palmateer, G., Cook, W.G., Maarschalkerweerd, J., Huber D., and Flood, K. 1984. Ultraviolet Disinfection of Secondary Effluent. *J. Wat. Pollut. Contl. Fed.* 56(7): 844–850.
- White, S.C., Jernigan, E.B., and Venosa, A.D. 1986. A Study of Operational Disinfection Equipment at Secondary Treatment Plants. *J. Wat. Pollut. Contl. Fed.* 58(3): 181–192.
- Wolf, H. W., Petrasek, A.C., and Esmond, S.E. 1979. Utility of UV “Disinfection” of Secondary Effluent. Progress in Wastewater Disinfection Technology – Proceedings of the National Symposium EPA-600/9-79-018 United States Environmental Protection Agency, Cincinnati, OH, USA.



AMERICAN ULTRAVIOLET COMPANY

- **Germicidal Ultraviolet Systems for Coil Irradiation**
- **In Duct - ACP Systems in widths from 12 to 65 inches**
- **Moisture Resistant Construction for Wet Applications**
- **Teflon Coated Lamps for sensitive areas**
- **High Output Lamps**
- **Electronic Ballasts**
- **Stainless Steel Construction**
- **2 Year Warranty**
- **UL Listed**

**Contact the Leader in Ultraviolet Technology.
Engineering Ultraviolet Systems Since 1960**

www.americanultraviolet.com
(800) 288-9288 Fax (765) 483-9525
mstines@americanultraviolet.com